

Die-Hard Cableless Tube Cleaning System

Model M5801



Tube & Pipe Cleaners ◦ Tube Testers ◦ Tube Plugs ◦ Tube Removal ◦ Tube Installation



Operating and Maintenance Instructions

Table Of Contents

Introduction, Serial Number Information	4
Safety	5
Startup Operation.....	8
Brush Sizing	12
Shut-Down Procedure.....	14
Electrical.....	15
Ground Fault Circuit Interrupter (GFCI) Test.....	17
Schematic	18
Maintenance.....	19
Preventative Maintenance Check List.....	22
Torque Chart.....	22
Technical Specifications.....	23
Troubleshooting.....	24
Parts List	26
Records.....	34

Introduction

Thank you for purchasing this Elliott product. More than 100 years of experience have been employed in the design and manufacture of our products, representing the highest standard of quality, value and durability. Elliott tools have proven themselves in thousands of hours of trouble free field operation.

If this is your first Elliott purchase, welcome to our company; our products are our ambassadors. If this is a repeat purchase, you can rest assured that the same value you have received in the past will continue with all of your purchases, now and in the future.

The Elliott Die-Hard has been designed for cutting tube bundles and shells in the following types of equipment:

Heat Exchangers

Condensers

Chillers

Evaporators

Air Conditioners

Tube cleaning increases operational efficiencies and reduces energy costs. For best results use the charts on pages 27 & 28 to keep track of your cleaning program. If you have any questions regarding this product, manual or operating instructions, please contact Elliott for immediate service.

Elliott Tool Technologies, Ltd.

1760 Tuttle Avenue, Dayton OH 45403, United States

Phone: +1 (937) 253 6133

Phone: +1 (800) 332 0447

Fax: +1 (937) 253 9189

Email: Sales@elliott-tool.com

Web: www.elliott-tool.com

Serial Number Information

The contents of this technical data manual apply only to Die-Hard Cableless Tube Cleaning system serial numbers beginning with revision letter 'C':

Example: C16001

Record your Die-Hard serial number here for future reference:

Model M5801-00 "Rev C" Serial # _____

Safety Instructions

Read and save all instructions. Before use, be sure everyone that will operate this machine reads and understands this manual, as well as any labels packaged with or attached to the machine.

⚠ WARNING

When using electric tools, certain safety precautions are required to reduce the risk of electrical shock and personal injury.

⚠ WARNING

To reduce the risk of injury, always unplug your machine before performing any maintenance. Never disassemble the machine or try to do any wiring on the electrical system. Contact Elliott for all repairs.

⚠ WARNING

 **ELECTRIC HAZARD:**
Use the proper lockout and tagout procedures before servicing machine.

⚠ WARNING

 **EYE HAZARD:**
Wear protective glasses.

NOTICE

Only use the Elliott Die-Hard Tube Brushes. These brushes have been designed to work with the Die-Hard Cleaner.

Safety Instructions (cont.)

Read all safety and operating instructions contained in this manual prior to use of the machine. Failure to follow all instructions listed below may result in electrical shock, fire and/or serious injury.

- Do not operate this machine while tired, distracted, under the influence of drugs or alcohol or on medication that causes decreased control.
- Do not use machine in wet conditions. Keep work area clean and well lit.
- Do not force a machine or attachment to do a job or operate at a speed it was not designed for.
- Check for misalignment, binding of moving parts, improper mounting, broken parts or any other conditions that may affect operation before use. Inspect all fasteners for tightness to ensure there are no loose nuts or bolts that may inhibit operation. Do not use a damaged machine. Repair or replace any defective parts prior to use of the machine.
- Use proper accessories and use Elliott accessories only. For all repairs, insist on only identical replacement parts.
- Always use properly grounded electrical outlets, and if using an extension cord, make sure that it is of the proper size for the electrical load and it is equipped with a ground wire and ground plug. See “Installation” on page 7 and “Electrical Systems” on page for further information.
- Use only extension cords and plugs approved for outdoor use when working outdoors.
- Use appropriate safety equipment (i.e. safety glasses, ear plugs, dust masks, safety boots, etc) when using this machine.
- Ensure that long hair or loose fitting clothes are secure prior to use of the machine.
- Always disconnect the machine from the power source prior to performing any maintenance or repairs.
- Labels and Nameplates carry important information and will assist you in ordering spare and replacement parts. If unreadable or missing, contact an Elliott service facility for a replacement.
- Maintain Machine Carefully. Keep handles dry, clean and free from oil and grease. Follow instructions for lubricating and changing accessories. For more information see “Maintaining the Die-Hard Cableless System” section. Periodically inspect the machine cord and extension cords for damage. Have damaged parts repaired or replaced by an Elliott service facility. Important data for oil change and antifreeze is contained in this section.

Safety Instructions (cont.)

- Store Idle Machines in the Horizontal Operating Position. When not in use, store your machine in a dry, heated, secured place. Always store your Die-Hard in its horizontal operating position. Not storing your Die-Hard in its horizontal operating position could result in pump oil loss through the Crankcase Check Valve Oil Cap (This cap is designed to release pressure buildup in crankcase at 1 PSI. When not stored in its horizontal operating position, oil will cover this Check Valve opening. When pressure buildup is released, oil could escape from crankcase and into the Die-Hard unit housing). For more information see “Maintaining the Die-Hard Cableless System” section.
- Stop the Machine Immediately if the Hose Stops Feeding. Hose damage will occur if the unit is operating when hose is restricted.
- Use the Proper Brush to fit the tubes to be cleaned. Never use a brush that is too large. Failure will result if too great a resistance is placed on the hose.
- Never place the Actuator in a vice or use pliers to grip the outside diameter of the Actuator. Use only the wrench flats provided to install or remove the Actuator from the Auto-Feed Hose. Use only the wrench flats provided to install or remove a brush from the Actuator shaft. Serious damage can be caused to the Actuator by placing it in a vice or other gripping device.
- Never leave your Die-Hard in Direct Contact with rain or directly spray water on the unit. Store indoors away from weather in a dry location.

WARNING

Never allow the actuator to be pulled into the Auto-Feed Pump Unit assembly. Serious damage will occur to both the Actuator and Auto-Feed Pump Unit Assembly.

Startup Operation

Read all of the operational instructions for your new Die-Hard Cableless Tube Cleaner. Its unique design incorporates features that will enable you to get the job done in less time and stay dryer. Many of these new features are unlike any on the market today and will require your attention to maintain and to use the Die-Hard to its full potential.

1. Position the Auto-Feed Pump Unit at a Right Angle to the tube sheet being cleaned. (Fig 1, Page 10) The Auto-Feed Gun Assembly connection is closest to the tube sheet being cleaned but is a minimum of 6' from the face of the tube sheet. When cleaning large diameter vessels, position the Auto-Feed Pump Unit facing the tube sheet being cleaned in the center of the tube sheet, keeping a minimum 6' distance to the tube sheet. Note: When moving from tube to tube, avoid sharp bends in the Auto-Feed Gun Assembly hose, keep the Auto-Feed Gun Assembly hose in generous arches from the handle to the Auto-Feed Pump Unit.
2. Unwind the Power Cord from the storage hooks.
3. Connect the Power Cord into an appropriate electrical source. Connect the Trigger Switch Feed Gun or Footswitch into socket flange mounting on the Die-Hard unit. Check "Reset" button on the GFCI to insure it is engaged. The "power" indicator light will be illuminated when power is flowing to the cleaner. For more information see "Electrical" section of this manual.
4. Connect a municipal water supply to the Auto-Feed Pump Unit. Be sure the Inlet Strainer is in place within the Hose Connection on the Auto-Feed Pump Power Unit before making this connection. This is a standard water hose connection and a garden hose can be used for this supply. A minimum 5/8" diameter hose is recommended.
5. Turn on the water pressure to the Auto-Feed Pump Unit, then immediately turn the water pressure off. This is done to prevent the pump from being operated "Dry". The quantity of water under pressure in the garden hose will supply enough water to the pump to prevent damage during the remainder of the set-up operation.
IMPORTANT: Never operate the Die-Hard Cableless Tube Cleaner dry. Damage to the high-pressure pump could result from operating the system without a connection to a water supply. Always follow the directions provided in this manual to prevent costly pump damage.
6. Uncoil Auto-Feed Hose and push the Actuator connection end into the Auto-Feed Pump Unit until it stops.
NOTE: Do not assemble Actuator to the Auto-Feed Hose at this time, serious damage will result if Actuator is pushed through the Feeding Unit in the Auto-Feed Pump Unit.
IMPORTANT: Do not push swivel fitting end into Auto-Feed Pump Unit. This will damage the Auto-Feed Hose and potentially the Auto-Feed Unit.
7. Depress the top side of Trigger Switch or "IN" side of the Footswitch (while applying a slight pushing motion to the Auto-Feed Hose. The Feeding Unit within the Auto-Feed Pump Unit will engage and pull the Auto-Feed Hose through the unit until it exits from the Auto-Feed Gun Assembly Connection. Allow approximately 12" of Auto-Feed Hose to exit the Auto-Feed Pump Unit and stop the feeding action of the hose by removing your finger from the Trigger, or foot from the Footswitch.

Startup Operation (cont.)

8. Uncoil the Auto-Feed Gun Assembly and install the correct clear nosepiece to the handle corresponding to the tube diameter being cleaned.
9. Locate the end of the Auto-Feed Gun Assembly, insert the exposed Auto-Feed Hose into the Auto-Feed Gun Assembly Connector, and connect it to the Auto-Feed Pump Unit. Screw the connector nut onto the Auto-Feed Gun Assembly connector **HAND TIGHT**. Do not over-tighten this connection; tools are not required for this operation.
10. Attach the clear plastic Drain Tube to the Feeding Handle. You may connect a standard garden hose to the end of the Drain Tube to provide additional length so water can be directed to a floor drain. Be aware that this tube will contain contaminants from tubes being cleaned.
11. With the Auto-Feed Gun Assembly hose in generous arches, grab the handle of Auto-Feed Gun Assembly. Depress the top side of the Trigger or “IN” side of Footswitch and allow the Auto-Feed Hose to be fed through the Auto-Feed Gun Assembly until approximately 6” of Auto-Feed Hose is exposed outside the nosepiece then stop.
IMPORTANT: When the Trigger or Footswitch is depressed a small amount of water will exit the Auto-Feed Hose Connection on the Auto-Feed Pump Assembly. This is normal and will occur each time the Trigger or Footswitch is depressed during set-up. This small quantity of water will keep the pump lubricated during the set-up operation.
12. Select the appropriate brush size for the tubes being cleaned. For more information see “Brush Sizing” section.
13. Select an Actuator and screw the correct size brush onto the Actuator. Locate the wrench flats on the Actuator and use the wrenches provided to tighten the brush and locknut to the Actuator Connection. Tighten the Locknut to the Actuator Connection to prevent the brush from coming loose during operation.
IMPORTANT: Never use a vise or pliers to hold the body of the Actuator when tightening brushes to the Actuator. Serious damage can occur to the Actuator if clamping pressure is applied improperly.
14. Screw the Actuator and brush to the connection on the Auto-Feed Hose. Remember use the wrench flats located on the Actuator with the wrenches provided to tighten this connection to the Auto-Feed Hose.
15. Lay Auto-Feed Hose in large loops on floor behind Auto-Feed Pump Unit. Loosen the screws that hold the Hose Stop Assembly on the Auto-Feed Hose and move the stop away from contact with the Auto-Feed Pump Unit.
16. The automatic stop is now ready to be set to the proper length of the vessel. Press on the top side of the Trigger or “IN” side of Footswitch and feed out a length of Auto-Feed Hose that is approximately the same length as the vessel being cleaned. Position the nosepiece against the tube sheet being cleaned, then walk to the opposite end of the vessel with the Actuator and brush assembly. Holding tension on the brush and Actuator make sure that only the brush will exit the opposite end of the vessel during the cleaning operation.
IMPORTANT: This measurement is critical; do not allow the Actuator to exit the tube during operation. Damage to the Auto-Feed Hose and Actuator can occur if the Actuator catches on the end of the tube during retraction of the Auto-Feed Hose.

Startup Operation (cont.)

17. Walk to the pump unit and slide the spring and Hose Stop Assembly over the Auto-Feed Hose until the end of the spring cap comes into contact with tube on the Auto-Feed Pump Unit. Depress the Hose Stop Assembly approximately 3" creating spring pressure against the tube end and tighten the screws on the Hose Stop Assembly with the wrench provided.
18. Depress the button side of the Trigger or "OUT" side of Footswitch to pull the Auto-Feed Hose and Feeding Nozzle back into the Handle Assembly. "Bump" or use repeated short Trigger or Footswitch pulses to return Actuator and brush assembly inside the clear Nozzle. Stop when the Actuator and brush assembly are visible in the clear nozzle.
19. Turn on the water pressure to the Auto-Feed Pump Unit.
20. Connect the Auto-Feed Hose to the Auto-Feed Pump Unit. This connection is supplied with a "quick slide" connector to eliminate hose rotation during operation.
21. The unit is now ready to clean tubes. Position the nozzle at the end of the first tube to be cleaned.
22. Depress the top side of the Trigger or "IN" side of Footswitch to start the feeding action of the cleaner.
NOTE: Keep the nozzle level and in contact with the tube at all times during the cleaning cycle. Keep the Trigger or Footswitch depressed until the pump unit automatically shuts off when the brush reaches the opposite end of the vessel being cleaned. Remove your finger from the top side of the Trigger or foot from Footswitch, move to the bottom side and depress the Trigger or "OUT" side of Footswitch.
23. The Auto-Feed Pump Unit will draw the Auto-Feed Hose back through the tube. Watch the returning Auto-Feed Hose through the clear Nosepiece Nozzle and stop the unit when the Actuator is visible in the clear Nozzle.
24. Move to the next tube and repeat the process until all the tubes have been cleaned.
25. Check all screw connections periodically to insure they are tight.
26. The machine is now ready to operate.

Startup Operation (cont.)

IMPORTANT: Monitor the travel of the Auto-Feed Hose through the clear nozzle or as the hose enters the Auto-Feed Pump Unit.

If an obstruction in the tube prevents the brush and Actuator from passing through the tube, remove your finger from the Trigger or foot from the Footswitch. Depress the bottom side or “OUT” side of Footswitch, and move the brush and Actuator about 2’ then depress the top side of the Trigger or “IN” side of Footswitch until the brush passes the tube restriction. If the brush and Actuator still will not pass, repeat the process of reversing direction slightly, then forward against the obstruction until it is clear. Do not keep the Trigger or Footswitch depressed if the Auto-Feed Hose is not moving through the tube. This will result in premature Auto-Feed Hose wear.

WARNING

This machine powers cleaning devices. It is recommended that the operator wear safety glasses with side shields or full face shield eye protection, gloves and water repellent, nonskid foot wear. Avoid contact with objects other than the tube when the machine is in operation.

NOTICE

Operate the Auto-Feed Handle Assembly as straight as possible to minimize any sharp radius bends. This applies to both brush insertion and maximum cleaning length. Allowing the cleaning device to exit the tube can cause premature failure in the Actuator Coupling area. Never exit the tube with the tube cleaning device in operation. For more information see “Start Up Operation” section.

NOTICE

Start to clean the tube bundle from the top of the unit to the bottom. Clean the bundle one row at a time, marking with soapstone, each row of tubes that have been cleaned.

Brush Sizing

Sizing your brushes correctly to the tubes being cleaned is a critical step in operating your Die-Hard Cableless Tube Cleaner. Its cleaning technique incorporates a unique design unlike any on the market today, and will require your attention to use your Die-Hard to its full potential.

Improper brush selection will prevent the “scrubbing” action of the system and will not allow the feeding of the brush through the tube.

1. Use a measuring device inside the tubes to determine the inside diameter of the tubes.
NOTE: Measure the tubes at a point away from the expanded section of the tube. An Elliott Tube Gage is recommended for this operation as it has an extended reach to enable this measurement to be taken at the appropriate location within the tube.
2. Select the brush diameter which is the closest to the measured tube ID. Note: Applies to both prime surface and internally enhanced tubes.

If no measuring device is available, use the following general brush sizing techniques:

1. For prime surface tubes and internally enhanced tubes, select a brush slightly smaller than the ID of the expanded portion of the tube.
2. Insert the brush onto the Actuator before connecting the Actuator to the Auto-Feed Hose. Using your thumb and forefinger holding the Actuator, insert the brush into the tube past the rolled /expanded area of the tube.
3. Pull the brush out of the tube. Since the brush is larger than the ID of the tube the bristles are slightly laid over in one direction. When pulling out the brush a resistance should be felt. Insert the next smaller brush size onto the Actuator and insert it into the tube past the rolled / expanded area.
4. Repeat this process until no resistance is felt and the brush slides freely in and out of the tube. The correct brush size for cleaning is the smallest brush size in which resistance is felt. This is to insure that the ends of the bristles are making contact with the tube wall, but not too large to restrict the feeding of the Auto-Feed Hose, and pulsing action of the Actuator.

IMPORTANT: These brush sizing techniques are regarded as general, and may vary depending on brush condition, tube deposit thickness, depth of internal enhancements, etc. Use only Elliott Die-Hard brushes. Do NOT select a brush with too large a diameter. This will impede the feeding of the Auto-Feed Hose, causing damage to its outer casing. If the Auto-Feed Hose feeds at a slower rate than its intended 3 ft/sec, try using the next brush size smaller in diameter.

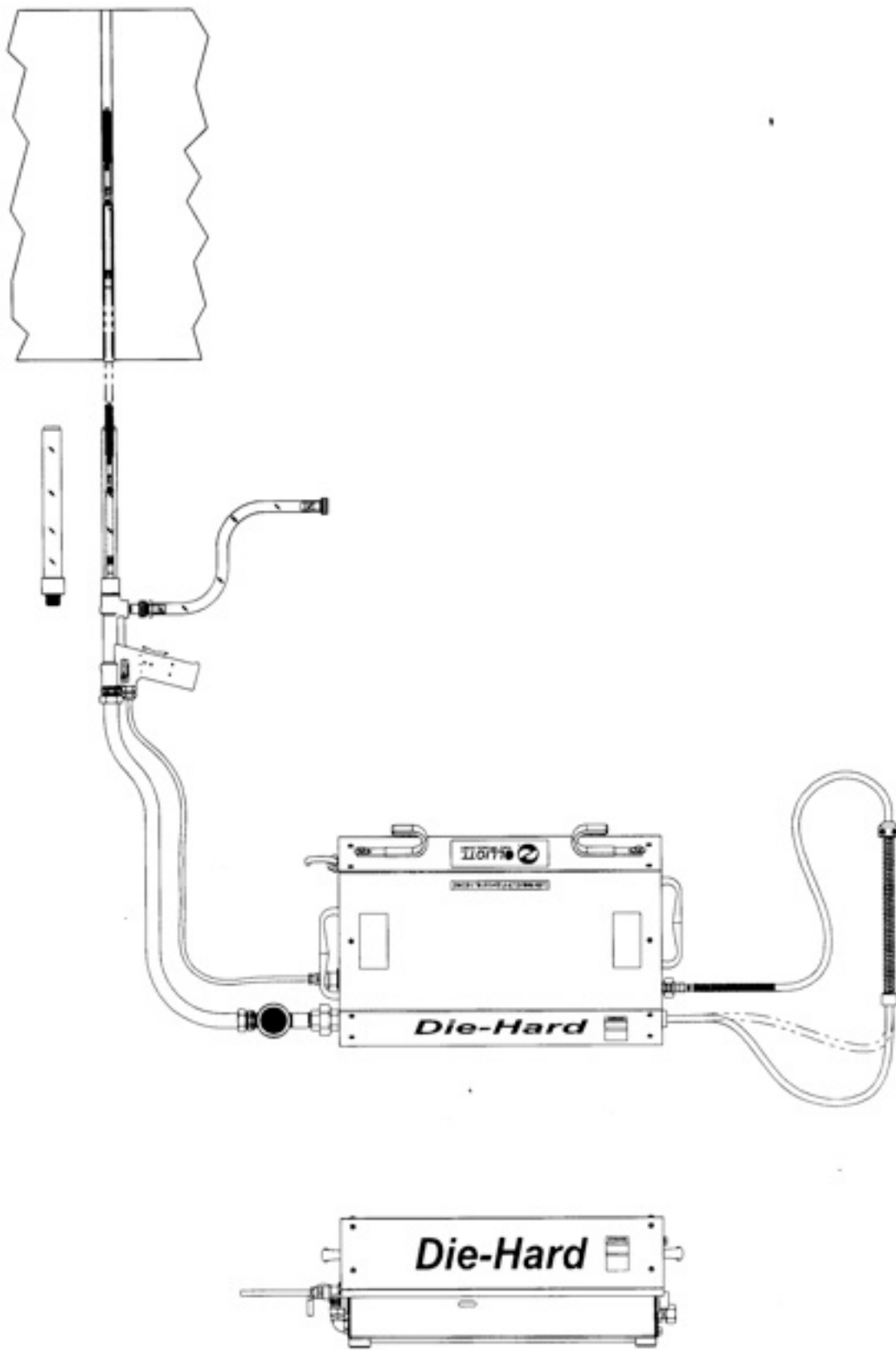

Operating Postion Fig. 1

Shut-Down Procedure

1. After all the tubes have been cleaned, shut off the water to the Auto-Feed Pump Unit.
2. Hold the Feeding Handle away from the tubes and tube sheet and depress the top side of the Trigger or “IN” side of Footswitch, feed out the brush and Actuator from the clear nozzle.
IMPORTANT: Serious damage will result if Actuator is pulled through the Feeding Unit in the Auto-Feed Pump Unit.
3. Remove the Actuator and brush from the Auto-Feed Hose. **DO NOT FEED THE ACTUATOR THROUGH THE AUTO-FEED PUMP UNIT.**
4. Disconnect the Auto-Feed Hose Assembly from the Auto-Feed Pump Unit
5. Depress the bottom side of the Trigger or “OUT” side of Footswitch and allow the Auto-Feed Hose to be pulled through the Auto-Feed Gun Assembly and Auto-Feed Pump Unit until the Auto-Feed Hose stops.
6. Remove the Auto-Feed Hose from the Auto-Feed Pump Unit.
7. Remove the Auto-Feed Handle Assembly from the Auto-Feed Pump Unit.
NOTE: If the Auto-Feed Pump Unit is exposed to freezing temperatures, Anti-Freeze Solution must be used to keep the pump from freezing.
8. Remove the Drain Tube from the Auto-Feed Handle Assembly and flush using clear water to remove any remaining contaminates from the tube cleaning operation.
9. Screw the “male” Drain Tube connector to the Auto-Feed Pump Unit hose connection.
10. Screw the Antifreeze Adapter onto the Elliott Antifreeze Bottle.
11. Screw the “female” end of the Drain Tube onto the Antifreeze Adapter.
12. Turn the container of Anti-Freeze Solution upside down allowing the Anti-Freeze Solution to fill the Drain Tube.
13. Activate the Auto-Feed Pump Unit by depressing either the top or bottom side of the Trigger or either side of Footswitch. **DO NOT ACTIVATE THE PUMP UNIT IF THE AUTO-FEED HOSE IS ENGAGED WITHIN THE AUTO-FEED PUMP UNIT.**
14. Watch the discharge of fluid from Auto-Feed Hose connection on the Auto-Feed Pump Unit.
15. When this discharge becomes the same color as the Anti-Freeze solution in the container, remove your finger from the Trigger or foot from the Footswitch and stop the unit.
16. Remove the Antifreeze Adapter from the Antifreeze container and replace the cap.
17. Remove the Drain Tube from the Auto-Feed Pump Unit.
18. Unplug the Power Cord from the electrical source and wind the Power Cord on the “hooks” provided on the Auto-Feed Pump Unit.
IMPORTANT: Store Die-Hard in its horizontal operating position only. Serious damage to pump could occur.

Electrical

Your Elliott Die-Hard has been designed to require a grounded electrical receptacle, of 120 volts, single phase, 20 amps, A.C. current. Serious damage to the unit can occur within the electrical components if the electrical supply, voltage and amperage rating does not meet this requirement. An electrical diagram is supplied with this manual as a reference (Fig 2, page 15). **Only a qualified electrician should use the electrical diagram to perform any maintenance or repairs.**

This machine requires electrical grounding. A three prong grounding plug must be used with this machine. The plug must be connected to a properly grounded outlet (see Diagram C). If the machine should electrically malfunction or breakdown, grounding provides a low resistance path to carry electricity away from the user, reducing the risk of electrical shock.

The grounding prong in the plug is connected through the green wire inside the cord to the grounding system in the machine. The green wire in the cord must be the only wire connected to the tool's grounding system and must never be attached to an electrically "live" terminal.

Your machine must be plugged into an appropriate outlet, properly installed and grounded in accordance with all codes and ordinances. A temporary adapter may be used for connecting grounded plugs to two prong outlets. The green rigid ear or lug extending from the adapter must be connected to a permanent ground such as a properly grounded outlet box or receptacle. Simply remove the center screw from the outlet, insert the adapter and reattach the screw through the green grounding ear to the outlet. If in doubt of proper grounding, contact a qualified electrician. A temporary adapter should only be used until a properly grounded outlet can be installed by a qualified electrician. (See Diagram D) The Canadian Electrical Code prohibits the use of temporary adapters.

WARNING

Improperly connecting the grounding wire can result in the risk of electric shock. Check with a qualified electrician if you are in doubt as to whether the outlet is properly grounded. Do Not modify the plug provided with the machine. Never remove the grounding prong from the plug. Do Not use the machine if the cord or plug is damaged. If damaged, have it repaired by an Elliott service facility before use. If the plug will not fit the outlet, have a proper outlet installed by a qualified electrician.

Diagram C

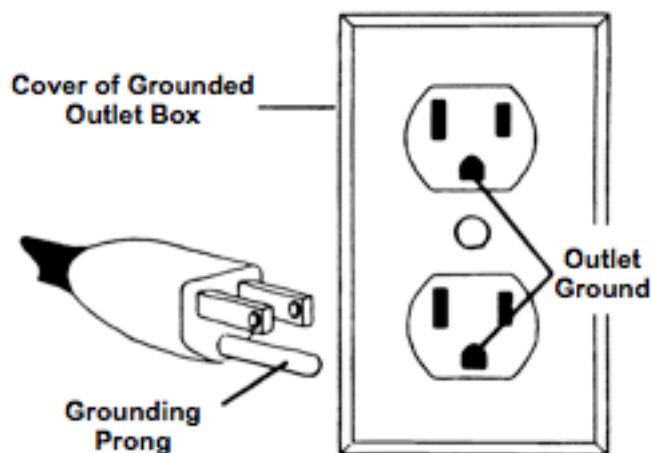
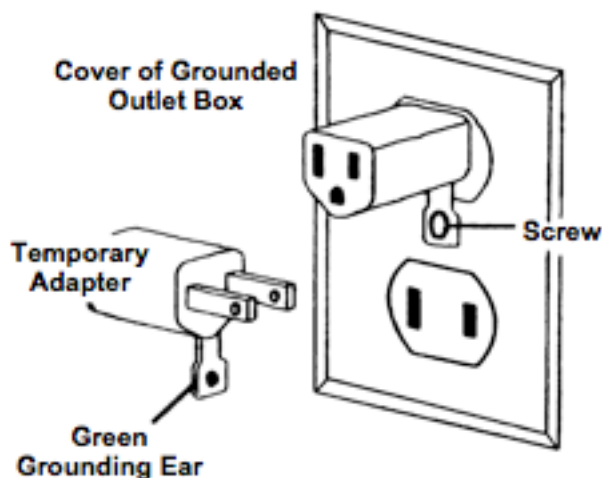

Diagram D



Extension cords may be used with the machine, providing the cord is equipped with three wires, 12 gauge in size, with ground plugs and not longer than 50' in length. Using extension cords with inadequately sized wire causes a serious drop in voltage resulting in possible machine damage. The smaller the gauge number of the wire, the greater the capacity of the cord. For example, a 12 gauge cord can carry a higher current than a 14 gauge cord.

- If you are using an extension cord outdoors, be sure it is marked with the suffix "W-A" ("W" in Canada) to indicate that it is acceptable for outdoor use.
- Be sure your extension cord is properly wired and in good electrical condition. Always replace a damaged extension cord or have it repaired by a qualified person before using it.
- Protect your extension cords from sharp objects and excessive heat.

GROUND FAULT CIRCUIT INTERRUPTER (GFCI) TEST

Your Elliott Die-Hard is equipped with a Ground Fault Circuit Interrupter located on the power cord. This device provides added protection in reducing the risk of electric shock. You should “test” the GFCI receptacle prior to each new operating use. Testing of the GFCI device is as follows:

1. Plug machine into proper electrical outlet.
2. Locate the Ground Fault Circuit Interrupter and push the “test” button with your finger. Never use any other device to push the test button.
3. An audible “click” should be heard when the button is depressed.
4. Engage the Trigger or Footswitch of the machine. The machine Should Not operate.
5. Release the Trigger or Footswitch of the machine, locate and push the “reset” button with your finger.
6. Engage the Trigger or Footswitch of the machine. The machine should operate normally.

WARNING

If the machine should fail this testing process, contact an Elliott service facility immediately. Do Not attempt to use the machine in this condition. An electric shock could occur if there is a malfunction of the GFCI circuit.

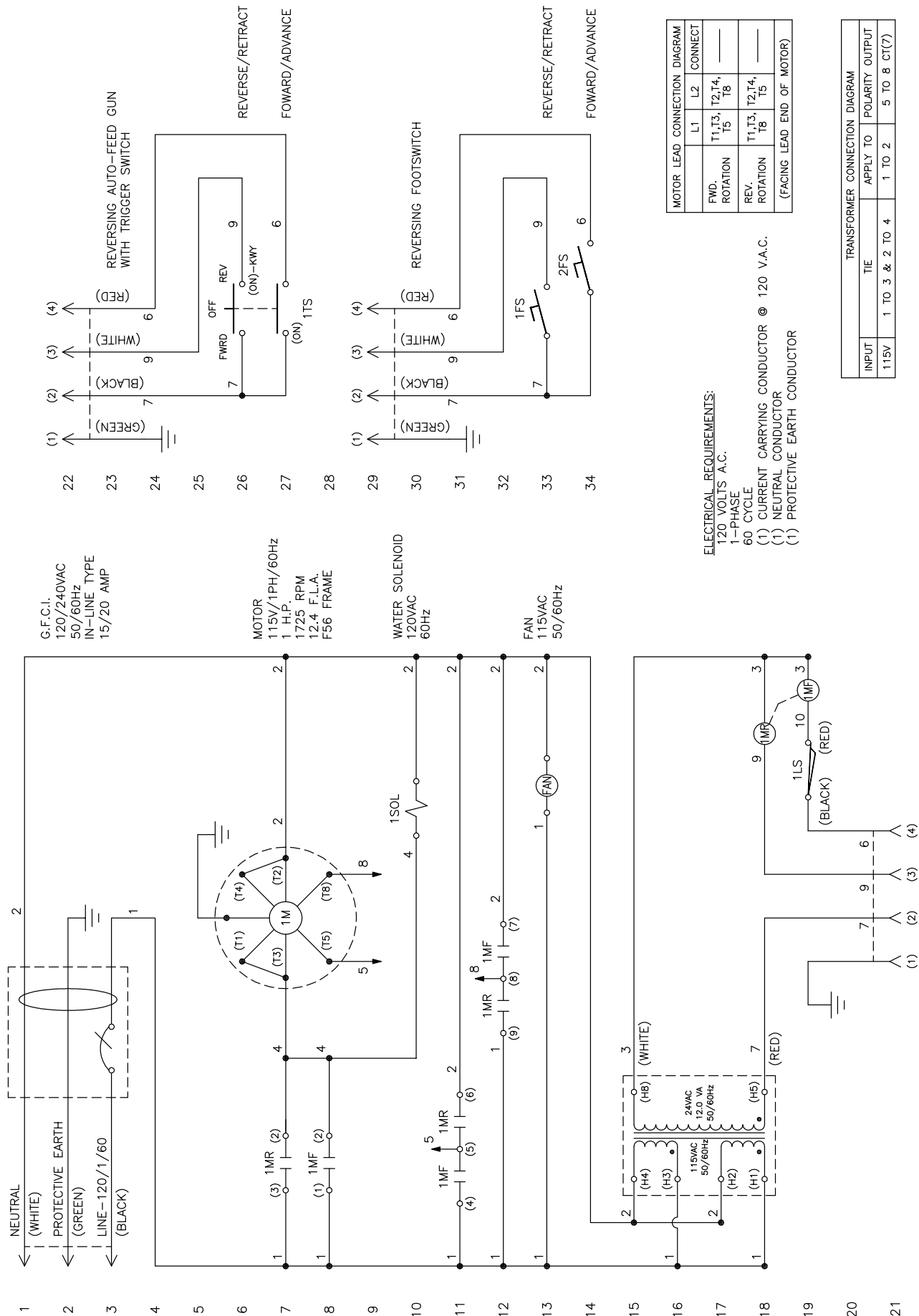

Schematic Fig. 2

Maintenance

WARNING

To reduce the risk of injury, always unplug your machine before performing any maintenance. Never disassemble the machine or try to do any rewiring on the machine's electrical system. Contact Elliott for all repairs.

Keep your Die-Hard in good repair by adopting a regular maintenance program. Before each use, examine the general condition of your machine. Inspect Trigger Switch connections, foot switch, machine cord set and extension cords for damage. Check for loose screws, misalignment, binding of moving parts, improper mounting, broken parts or any other condition that may affect its safe operation. If abnormal noise or vibration occurs, turn the machine off immediately and have the problem corrected before further use. For more information see "Trouble Shooting" section. **DO NOT USE A DAMAGED MACHINE.** Tag damaged machines "DO NOT USE" until repaired.

Under normal conditions lubrication of the machine between uses is not necessary.

Clean dust and debris from vents. Keep the machine handles clean, dry and free of oil or grease.

Your machine has been finished with a paint coating that is very durable and should last the life of the machine. Use only mild soap and a damp cloth to clean your machine. Certain cleaning solvents may be harmful to the painted surfaces. Never use flammable or combustible solvents around machines.

WARNING

DO NOT expose the pump and valves within the Auto-Feed unit to freezing temperatures, without antifreeze protection.

After every cleaning season or 12 months remove the machine cover and check the "V" belt for cracking and wear. Start the next cleaning season by operating the machine prior to starting a new job. For more information on proper operation see "Operation" section.

Maintenance (cont.)

Antifreeze

If the unit will be exposed to freezing temperatures the pump and valves within the Auto-Feed Pump Unit need to be protected against freezing. A high quality antifreeze solution must be used to prevent damage to the ceramic pistons within the high-pressure pump. Use only approved antifreeze products listed below; unapproved products could cause damage to the seals within the pump.

- Antifreeze solution supplied by Elliott (Propylene Glycol)
- Ethylene glycol based automotive antifreeze

IMPORTANT: Ethylene Glycol based automotive antifreeze is toxic, follow directions for its proper use, handling, disposal and storage. Elliott antifreeze is non-toxic and is generally regarded as safe by U.S. Government.

If unit has been exposed to freezing temperatures, allow the unit time to “warm up” prior to using.

Crankcase Oil Change

Change the oil in the pump crankcase after first 50 hours of operation. Follow the schedule on the “Preventative Maintenance Check-List” (Fig 3) thereafter, or at the end of every cleaning season.

1. Insure that the power cord has been removed from any 120 Volt power source.
2. Remove the cover of the Auto-Feed Pump Unit by removing the 10 Phillips Head Screws.
3. Locate the Crankcase Check Valve on the top of the Pump Crankcase.
4. Remove the Crankcase Check Valve.
5. Place an oil drain pan on a flat surface.
6. Use the two grab handles on each end of the Auto-Feed Pump Unit and turn the unit upside down with the draining oil from the Pump Crankcase flowing into the drain pan.
7. After all of the oil has drained from the Pump Crankcase rotate the unit back to the upright position.
8. Use a soft cloth to wipe up any spilled oil from the inside of the Auto-Feed Pump Unit Housing.
9. Use a funnel to assist in filling the Pump Crankcase with only SAE 30 NON-DETERGENT OIL.
IMPORTANT: Use only SAE 30 NON-DETERGENT OIL in the Pump Crankcase, use of a Detergent type oil will damage internal pump components and void manufacturers warranty.
10. Check oil level using the Site Gage on the end of the Crankcase Housing. Fill slightly past the RED DOT on the Site Gage. **DO NOT FILL PAST SITEGLASS TOP!**
11. Replace the Crankcase Check Valve in the Pump Crankcase.
12. Replace the cover and secure with the 10 Phillips Head Screws.

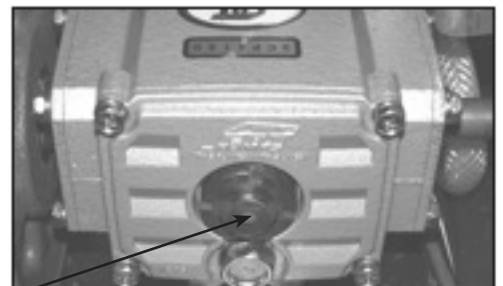
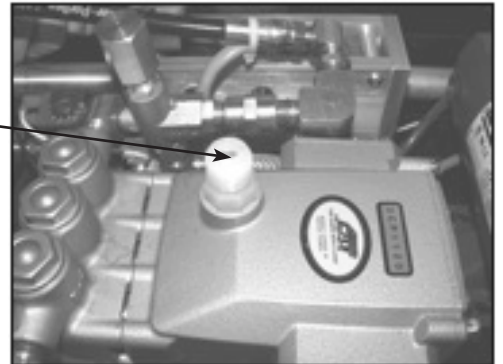

Inspect the Auto-Feed Hose connections for wear or abrasion after each cleaning session. Inspect the Actuator for loose components or free “play” of the brush attachment. If excess play is discovered, the spring within the Actuator will require replacement. See “Actuator” Section.

Maintenance (cont.)

Actuator

To replace the Actuator spring:

1. Loosen the 3 Stainless Steel set screws on Brush Adapter.
2. Apply localized heat to the Brush Connector threads to approximately 250°C. Disassemble while hot. Remove Brush Adapter by unthreading from the Piston Rod. A screwdriver slot has been supplied at the back of the Actuator to assist in this removal process. Remove the nylon washer. Use a thread locking solvent and mechanical abrasion such as a wire brush to clean threads.
3. Apply localized heat to the Rear Adapter threads to approximately 250°C. Disassemble while hot. Use wrench flats to remove the Rear Adapter from the Actuator. Use a thread locking solvent and mechanical abrasion such as a wire brush to clean threads.
4. Remove the Piston, Spring, and Piston Rod from the body of the Actuator.
5. Remove and replace the Spring from the Piston Rod. Reassemble in reverse order. Remember to use a medium to high strength thread locking compound when replacing the Rear Adapter and Brush Connector – do not apply to Set Screws.

NOTE: Do not allow thread locking compound to enter the Piston area of the Actuator.

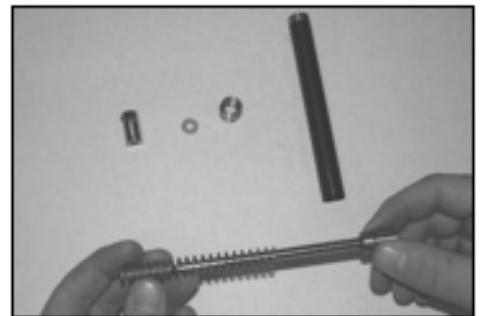
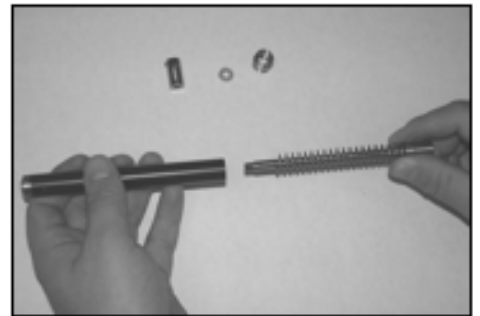
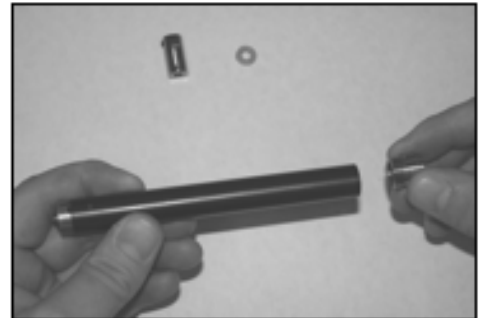
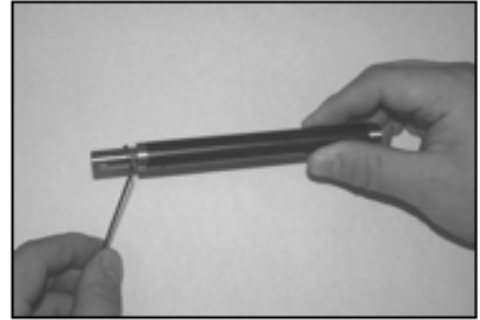

Preventative Maintenance Checklist

Check	Daily	Initial 50 Hours	200 Hours	500 Hours*	1500 Hours**	3000 Hours**
Clean Inlet Strainer	X					
Clean Solenoid Strainer			X			
Oil Leaks	X					
Water Leaks	X					
Belts, Pulley		X		X	X	X
Plumbing		X		X	X	X
Initial Oil Change SAE 30 Non-Detergent		X				
Oil Change SAE 30 Non-Detergent				X	X	X
Seal Change						X
Valve Change						X

Valves typically require changing every other seal change. Duty cycle, temperature, quality of pumped water, and inlet feed conditions effect the life of the pump, wear parts and service cycle.

** Remember to service the regulator/unloader at each seal servicing and check all system accessories and connections before resuming operation.

Refer to this manual for additional assistance.

*Oil Change SAE 30 Non-Detergent every 500 hours.

Torque Chart

Item Description	Thread	Fastener Size	Torque		
			in. lbs.	ft. lbs.	Nm
Plunger Retainer	M6	M10 Hex	55	4.4	6.2
Manifold Screw	M8	M6 Allen	115	9.58	13
Valve Plugs	M22	M22	870	72.5	98
Bearing Cover Screws	M6	M10 Hex/Phillips	50	4	5.4
Rear Cover Screws	M6	M10 Hex/Phillips	50	4	5.4
Connecting Rod Screws	M7	M10 Hex	95	8	11
Bubble Oil Site Gage	M28	Oil Gage Tool	45	3.8	5
Direct Mount Bolts	M7	M10 Hex	95	8	11

Fig 4

Technical Specifications

Motor

1/2 H.P. Electric Motor, 115/208-230 Volts, Single Phase, 60 Cycles, 8.5/4.10-4.25 Amps.

Pump

4.2 GPM Max., 100-2200 PSI Max., 1725 RPM Max. Crankcase Oil Capacity 11.5 oz.

G. F. C. I. Electrical Rating

120 Volts, 15 Amps, 1800 Watts, 50/60 Hz.

Dual Voltage Power Transformer

115/230 Volts, 50/60 Hz, 24.0 Volts CT @ 0.5 Amps Output

Trigger / Footswitch Socket Flange Mounting

24.0 Volt Control

Overall Base Size (w/ cover)

24.3" x 15.03" x 9.6" (617.2 x 381.0 x 243.8 mm)

Connections

3/4" Hose Connection, 1/8-27NPT Auto-Feed Hose Connection

Unit Weight w/out Auto-Feed Accessories

97 lbs. (44.0 kg)

Total Unit Weight w/ Auto-Feed Accessories

104 lbs. (47.2 kg)

Troubleshooting

PROBLEM	PROBABLE CAUSE	SOLUTION
No Power Flow	GFCI not in "Reset" mode	Press "Reset" button on GFCI located at plug connection of power cord
Hose Not Feeding - Feeding unit not rotating	Pump shaft rotates but feeding unit does not rotate	Check set screw in coupling jaw, tighten screw
Hose Not Feeding - Feeding unit rotates	Hose will not feed out side of tube	Check hose casing for grease or oil, wipe off hose casing
	Hose will not feed inside of tube	Check tube ID if measurement is less than .520" tube is too small
	Hose will not feed, pump is not pumping water	Check belt tension, replace belt if broken
	Hose feeds into tube but stops	Tube is obstructed, back up & try again if unable to pass tube is blocked
Actuator	Brush on Actuator moves a short distance easily by hand	Broken Actuator Spring, replace Actuator Spring
	Actuator does not move during operation	Actuator Body is bent, replace Actuator
Auto-Feed Hose Assembly	Hose feeds past initial stop setting	Tighten Stop Coupling cap screws
Low Pressure	Belt slippage	Tighten belt or install new belt
	Air leak in inlet plumbing	Tighten hose fitting
	Relief valve stuck, partially plugged or improperly adjusted	Clean/adjust relief valve. Replace defective components
	Inlet strainer clogged	Clean filter and replace in hose connection
	Solenoid strainer clogged	Clean strainer and replace solenoid
	Leaky Auto-feed Hose	Replace Auto-feed Hose
	Inadequate water supply	Check for water flow in inlet hose, or replace with larger diameter hose
	Worn seals	Install new seal kit
Water Leak - Under the unit	Worn or dirty inlet/discharge valves	Clean inlet/discharge valves or install new valve kit
	Worn seals	Install new seal kit
	Worn adapter "O" Rings	Install new "O" Rings
Water Leak - Into the crankcase	Fitting loose	Tighten fitting or replace fitting
	Humid air condensing into water inside crankcase	Install oil cap protector, change oil every 3 months or 500 hours
	Excessive wear to seals and V-Packings	Install new seal kit

Troubleshooting

PROBLEM	PROBABLE CAUSE	SOLUTION
Lack Of Cleaning Power/ Poor Cleaning	Loose belt	Tighten belt
Knocking Noise - Inlet supply	Inadequate inlet water supply	Make sure water supply is turned on to the unit
Knocking Noise - Bearing	Broken or worn bearing	Replace bearing
Knocking Noise - Pulley	Loose pulley on crankshaft	Check key & tighten set screw
Knocking Noise - Coupling	Loose coupling on shaft between pump & feeding unit	Check neoprene "spider" between coupling jaws, replace if worn
Oil Leak - Crankcase oil seals	Worn crankcase oil seals	Replace crankcase oil seals
Oil Leak - Crankcase oil seals & O-rings	Worn crankcase oil seals or O-rings on bearing cover	Remove bearing cover and replace O-rings and/or seals
Oil Leak - Drain plug	Loose drain plug or worn drain plug O-ring	Tighten drain plug or replace O-ring
Oil Leak - Bubble gage	Loose bubble gage or worn bubble gage gasket	Tighten bubble gage or replace gasket
Oil Leak - Rear cover	Loose rear cover or worn rear cover O-ring	Tighten rear cover or replace O-ring
Oil Leak - Crankcase check valve	Loose check valve, excessive oil in crankcase or stored in a position other than its horizontal operating position	
	Tighten check valve, fill crankcase to specified level, store unit in a horizontal operating position	
Pump Runs Rough - Inlet conditions	Restricted inlet or air entering the inlet plumbing	Correct inlet size plumbing, check for tight seal on hose connection
Pump Runs Rough - Pump valves	Stuck inlet/discharge valves	cleanout foreign material or install new valve kit
Pump Runs Rough - Pump seals	Leaking V-Packings	Install new seal kit
Premature Seal Failure	Scored plungers	Replace plungers
	Running pump dry	DO NOT RUN PUMP WITHOUT LIQUID
	Starving pump of adequate water	Increase hose one size larger than inlet port size

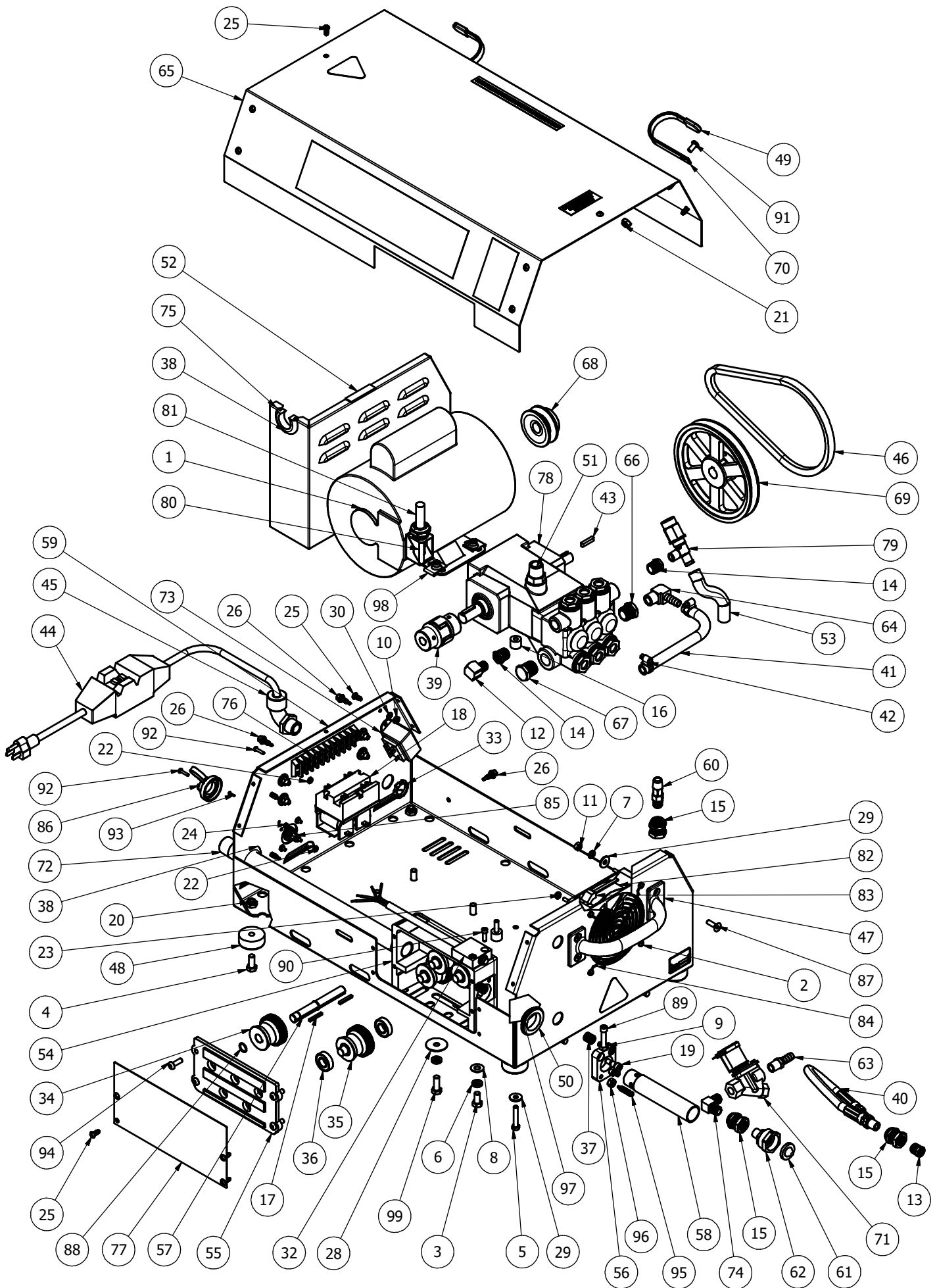

Die-Hard Parts List M5801-21

PARTS LIST				PARTS LIST			
ITEM	QTY	PART NUMBER	DESCRIPTION	ITEM	QTY	PART NUMBER	DESCRIPTION
1	1	06201	1 HP MOTOR	54	1	M5801-01-201	GEAR HOUSING
2	4	127C	ROUND HEAD MACHINE SCREW, #8-32 X 2-1/4	55	1	M5801-01-202	SIDE PLATE
3	5	130BB	HEX HEAD CAP SCREW, 5/16-18 X 5/8	56	1	M5801-01-204	STOP PLATE
4	4	130BC	HEX HEAD CAP SCREW, 5/16-18 X 3/4	57	1	M5801-01-205	DRIVE SHAFT
5	4	131A	HEX HEAD CAP SCREW, M6 X 1.0 X 35MM	58	1	M5801-01-207	INLET FEED TUBE
6	9	133A	LOCK WASHER, 5/16	59	1	M5801-01-211	HOUSING BASE
7	8	133M	LOCK WASHER, M6	60	1	M5801-01-2111	MALE CONNECTOR BARB
8	5	169U	WASHER, 5/16, 18-8 STAINLESS STEEL	61	1	M5801-01-2114	FILTER SCREEN
9	1	171A	HEX NUT, 1/4-20	62	1	M5801-01-2115	GARDEN HOSE ADAPTER
10	1	171SS	HEX NUT, #10-32	63	1	M5801-01-2116	HOSE BARB ADAPTER
11	8	171W	HEX NUT, M6	64	1	M5801-01-2117	ELBOW HOSE BARB ADAPTER
12	1	41-50785K431	1/4 STREET ELBOW	65	1	M5801-01-212	HOUSING COVER
13	1	41-50785K61	HEX BUSHING, 1/4 X 1/8	66	1	M5801-01-2120	HEX BUSHING, 1/2 X 3/8
14	2	41-50785K63	HEX BUSHING, 3/8 x 1/4	67	1	M5801-01-2121	1/2 HEX HEAD PLUG
15	3	41-5454K87	1/4 BULKHEAD FITTING	68	1	M5801-01-2127	SHEAVE
16	4	41-92510A777	SPACER	69	1	M5801-01-2129	SHEAVE
17	2	41-98870A110	KEY, 1/8	70	2	M5801-01-213	CORD WRAP
18	1	52-997171	24V MOTOR REV CONTACTOR	71	1	M5801-01-2139	SOLENOID VALVE
19	2	539F	SHOULDER SCREW, 1/4-20 X 3/8	72	1	M5801-01-2150	EXIT FEED TUBE
20	4	546C	ELASTIC LOCKNUT, 5/16-18	73	1	M5801-01-2152	TRANSFORMER
21	2	546D	ELASTIC LOCKNUT, 1/4-20	74	1	M5801-01-2155	1/4 MALE ELBOW
22	6	546E	ELASTIC LOCKNUT, #6-32	75	1	M5801-01-2163	ENCLOSURE
23	4	546H	ELASTIC LOCKNUT, #8-32	76	1	M5801-01-2174	TERMINAL STRIP
24	1	546Y	ELASTIC LOCKNUT, #2-56	77	1	M5801-01-2181	GUARD
25	15	577-4	THREAD-CUTTING SCREW, #10-32	78	1	M5801-01-2182	HIGH PRESSURE WATER PUMP
26	7	584-1	HEX HEAD DRILLING SCREW, #12-14 X 3/4	79	1	M5801-01-2184	PRESSURE REGULATOR
28	4	587-1	FENDER WASHER, 5/16	80	1	M5801-01-2191	SNAP ELBOW STRAIN RELIEF
29	12	587-2	FENDER WASHER, M6	81	36	M5801-01-2192	CABLE
30	1	595-1	EXTERNAL TOOTH LOCK WASHER, #10	82	1	M5801-12	FAN
31	1	ETTLBL5500A	LOGO LABEL	83	1	M5801-13	FAN POWER CORD
32	1	M5360D5-22	SWITCH	84	1	M5801-15	WIRE FAN GUARD
33	1	M5631D14	LOCK NUT, 1/2	85	1	M5808-09	SOCKET FLANGE MOUNTING
34	1	M5801-01-03B	DRIVE GEAR	86	1	M5808-12	FLANGE MOUNTING CAP
35	4	M5801-01-03C	GEAR	87	8	P535-28	FLAT HEAD CAP SCREW, M6 X 20
36	10	M5801-01-0718	DEEP GROOVE BALL BEARING	88	2	P8286-50NS	RETAINING RING, SPIRAL, EXTERNAL, 2 TURN, 1/2
37	2	M5801-01-0724	STOP SPRING	89	1	P8302-184	SOCKET HEAD CAP SCREW, 1/4-20 X 1-3/4
38	2	M5801-01-0732	GROMMET	90	2	P8302-46	SOCKET HEAD CAP SCREW, #10-24 X 5/8
39	1	M5801-01-078	JAW COUPLING	91	2	P8597-10	BUTTON HEAD CAP SCREW, 1/4-20 X 1/2
40	1	M5801-01-1113	DISCHARGE HOSE	92	6	P8597-45SS	BUTTON HEAD CAP SCREW, #6-32 X 5/8
41	8.25	M5801-01-1118	REINFORCED PVC TUBING	93	1	P8597-50	BUTTON HEAD CAP SCREW, #2-56 X 3/8
42	2	M5801-01-1119	WORM DRIVE CLAMP	94	4	P8597-9SS	BUTTON HEAD CAP SCREW, 1/4-20 X 3/4, SS
43	2	M5801-01-1123	KEY, 5MM	95	2	41-8688A161	SPRING PLUNGER
44	1	M5801-01-1124	GFCI POWER CORD	96	2	171AA	HEX NUT, 1/4-28
45	1	M5801-01-1125	CORD CONNECTOR	97	1	P8398-143	RETAINING RING, SPIRAL, EXTERNAL, SINGLE TURN, 1-7/16
46	1	M5801-01-1126	BELT	98	4	M5801-22	CLIP-ON BARREL NUT, 5/16-18 MODIFIED
47	2	M5801-01-1131	HANDLE	99	4	130BD	HEX HEAD CAP SCREW, 5/16-18 X 7/8
48	4	M5801-01-1132	FOOT				
49	2	M5801-01-114	VINYL CAP				
50	1	M5801-01-209	GUIDE RING				
51	1	M5801-01-1153	BALL CHECK VALVE				
52	45	M5801-01-1164	ADHESIVE FOAM STRIP				
53	4.5	M5801-01-119	CLEAR VINYL TUBING	-	-	M5801-01-2185	CRANKCASE OIL, 21OZ

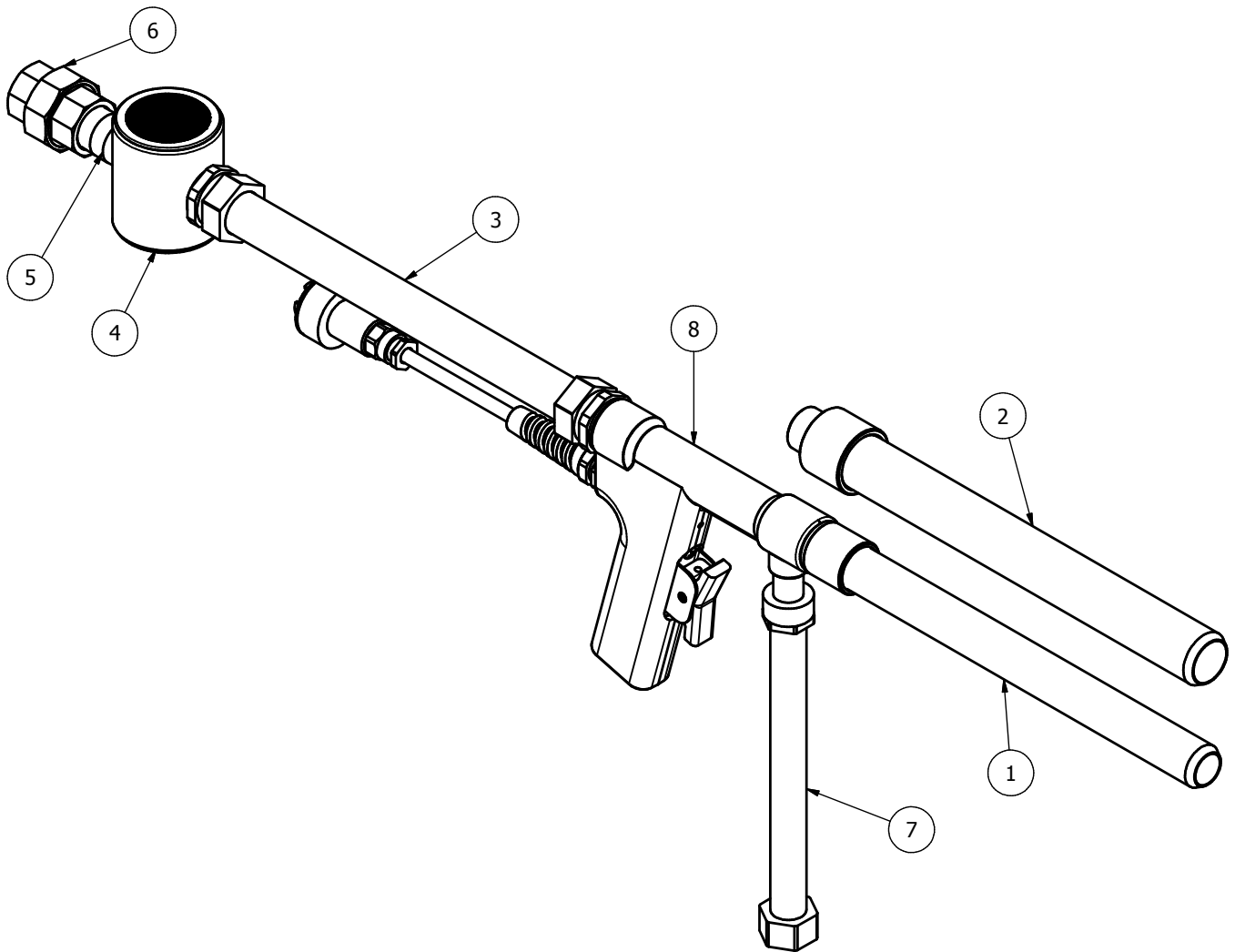

PARTS LIST			
ITEM	QTY	PART NUMBER	DESCRIPTION
1	1	M5801-03-01	3/4" GUN NOZZLE
2	1	M5801-03-02	1" GUN NOZZLE
3	1	M5801-03-03	AUTO-FEED CASING
4	1	M5801-03-05	DRAIN PORT
5	1	M5801-03-06	LONG PIPE NIPPLE
6	1	M5801-03-07	3/4 UNION
7	1	M5801-03-08	DRAIN HOSE
8	1	M5808-20	TRIGGER SWITCH ASSEMBLY

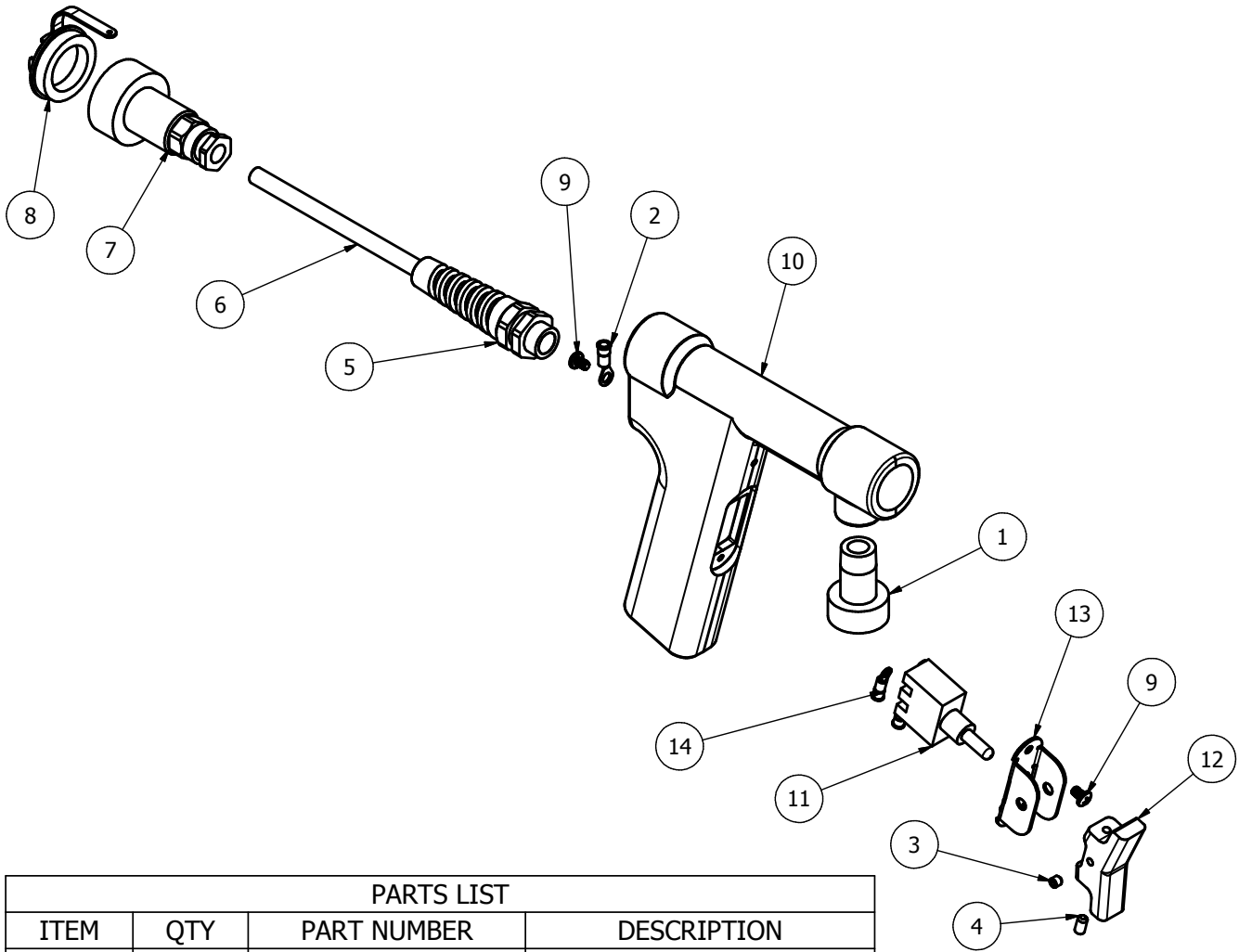

PARTS LIST			
ITEM	QTY	PART NUMBER	DESCRIPTION
1	1	07107	SWIVEL CONNECTOR
2	1	07119-4	INSULATED RING
3	2	128BC	CUP POINT SET SCREW, #10-24 X 3/16
4	2	128DD	CUP POINT SET SCREW, #10-24 X 3/8
5	1	M5808-04	STRAIN RELIEF
6	200	M5808-05-01	CABLE
7	1	M5808-05-02	PIN SCREW CONNECTOR
8	1	M5808-05-03	SCREW CONNECTOR CAP
9	3	M5808-06	PAN HEAD PHILLIPS SCREW, #8-32 X 1/4
10	1	M5808-21-01	FEED GUN HANDLE
11	1	M5808-21-02	TOGGLE SWITCH
12	1	M5808-21-06	TRIGGER
13	1	M5808-21-07	SWITCH GUARD
14	3	M5808-21-09	INSULATED RING

PARTS LIST			
ITEM	QTY	PART NUMBER	DESCRIPTION
1	1	M5801-02-04	MALE RIGID FITTING
2	1	M5801-02-04P	MALE CRIMP FITTING
3	1	M5801-02-05	SPRING
4	1	M5801-02-06	SPRING CAP
5	1	M5801-02-07	STRAIN RELIEF SPRING
6	1	M5801-02-08	STOP COUPLING
7	1	M5801-02-11	MALE COUPLER
8	1	M5801-02-12	NIPPLE

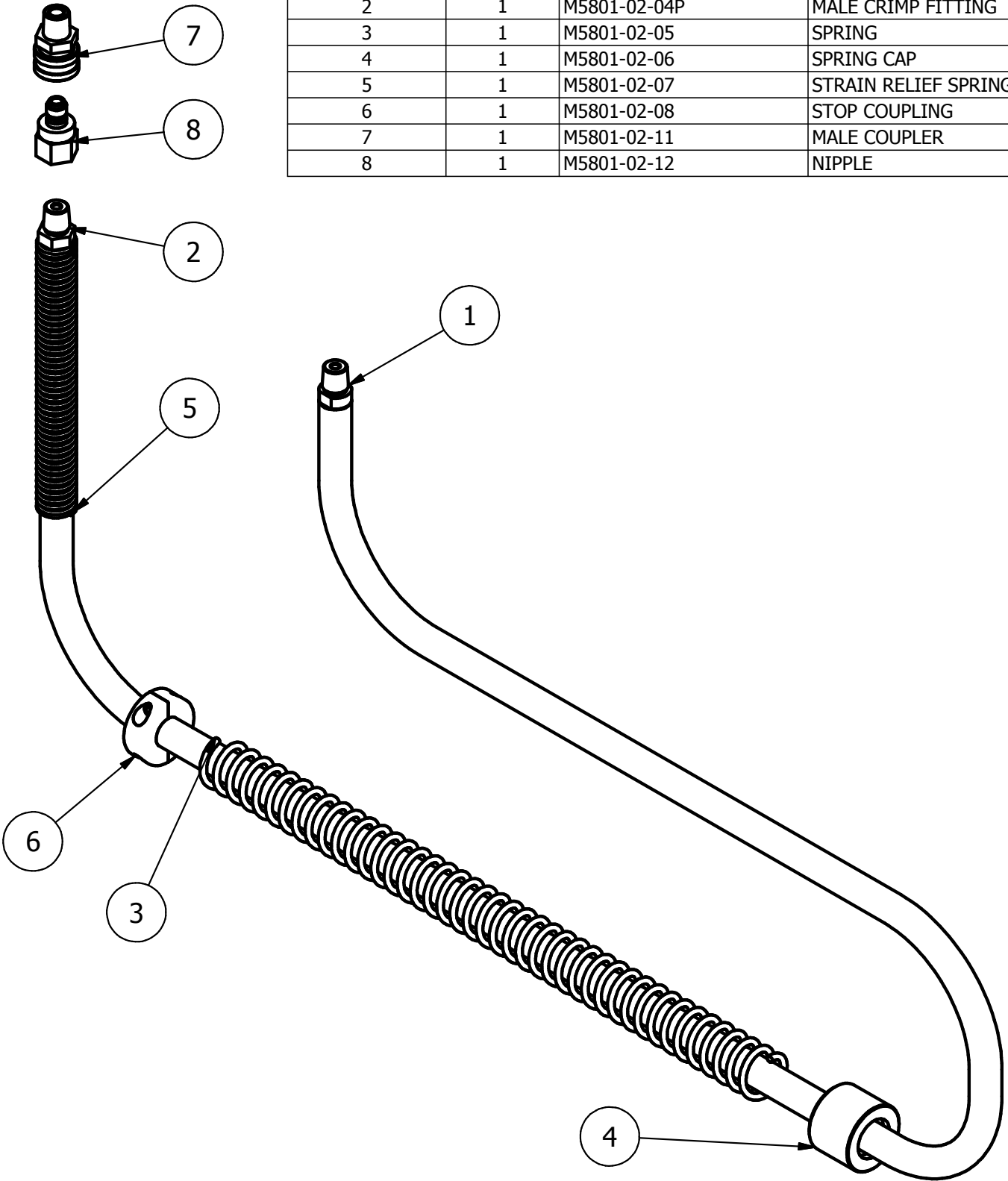

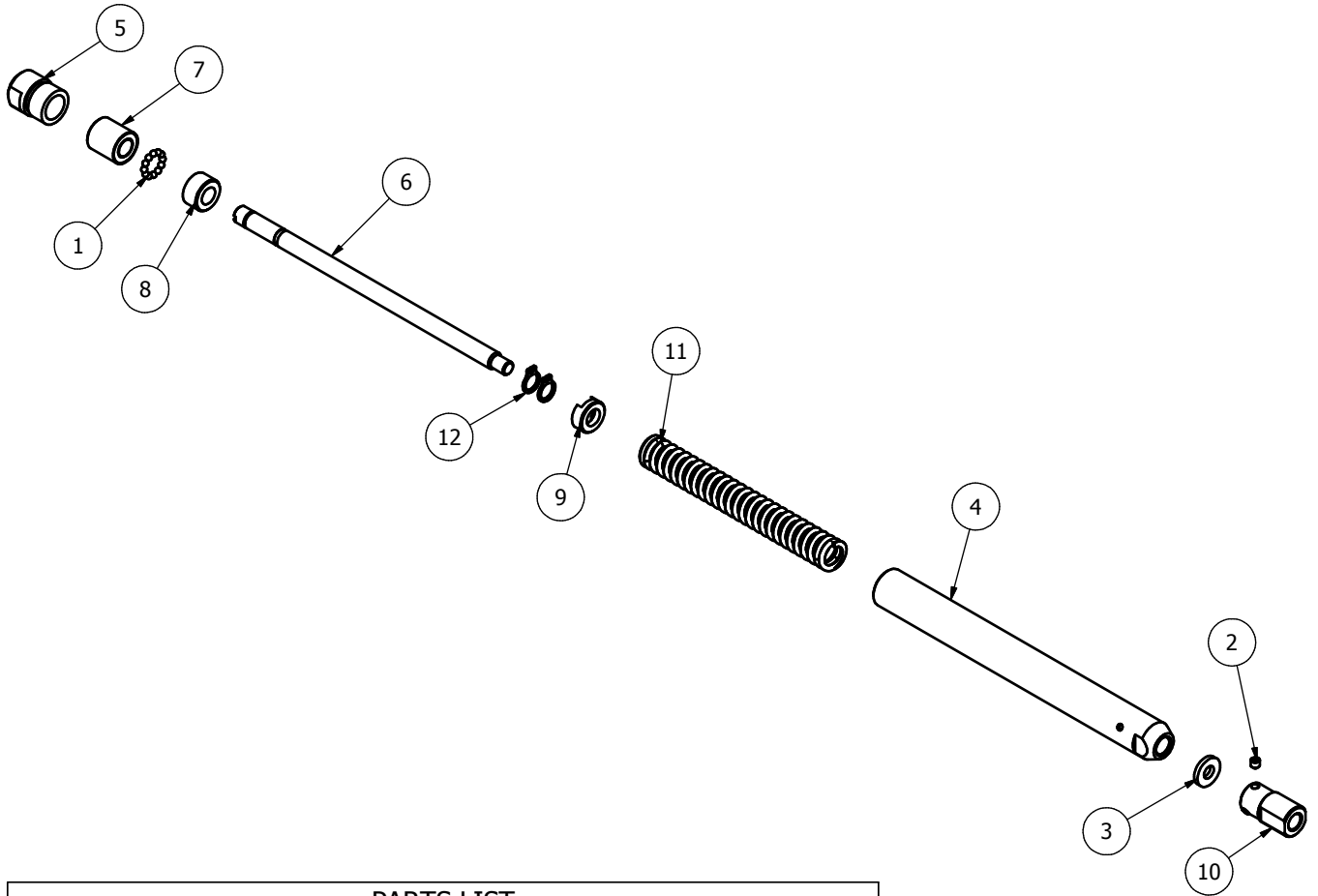

PARTS LIST			
ITEM	QTY	PART NUMBER	DESCRIPTION
1	12	109CBS	BALL, 2MM
2	3	128EGS	CUP POINT SET SCREW, M3x.5 X 3
3	1	591-14	NYLON WASHER, #8
4	1	M5801-04-01	BODY
5	1	M5801-04-02	REAR ADAPTOR
6	1	M5801-04-031	PISTON ROD
7	1	M5801-04-032	PISTON
8	1	M5801-04-033	RACE
9	1	M5801-04-034	RETAINING RING COVER
10	1	M5801-04-04	BRUSH CONNECTOR
11	1	M5801-04-05	SPRING
12	2	P8375-25SS	RETAINING RING

Accessories

M5807-00 Parts List

Item	Description	Part Number	Qty.
	Contractor Dolly	M5807-00	
1	Linch Pin	M5807-03	2
2	Pneumatic Tire	M5807-07	2
3	Spacer	M5807-06	2
4	Adjustable Latch	M5807-05	2
5	Frame	M5807-01	1
6	Finishing Plug	06019	4
7	Snap Pin	M5807-04	2
8	Handle	M5807-02	1

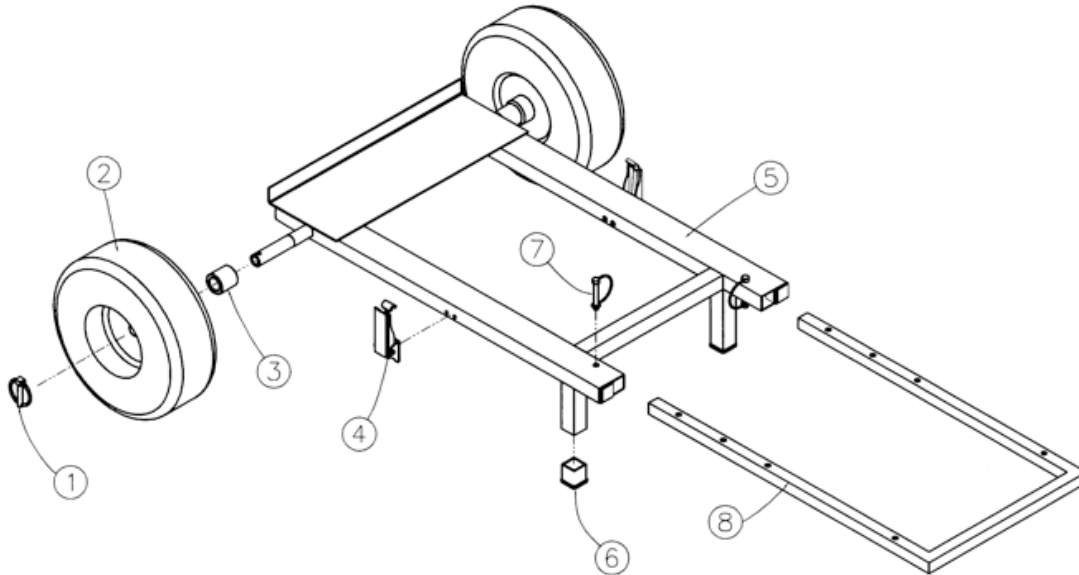

Optional Footswitch M5801-10

Item	Description	Part Number	Qty.
	Footswitch	M5801-10	
1	Pin Screw Connector	M5808-05-02	1
2	Cap	M5808-05-03	1

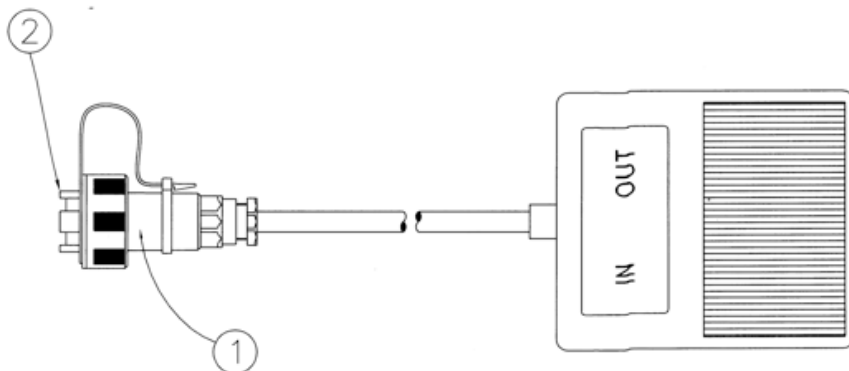

This page intentionally left blank.

Elliott Charts For Recording Cleaning Schedules And Efficiencies

EFFICIENCY %		DATE OF CLEANING
BEFORE CLEANING	AFTER CLEANING	

EFFICIENCY %		DATE OF CLEANING
BEFORE CLEANING	AFTER CLEANING	



Contact Us

Elliott Tool offers a complete line of precision tube tools to meet your needs. Contact us or your local support.

Elliott Tool Technologies, Ltd.
1760 Tuttle Avenue
Dayton, Ohio 45403-3428
Phone: +1 937 253 6133 • +1 800 332 0447
Fax: +1 937 253 9189
www.elliott-tool.com

Printed in the USA
©12/2017 Elliott Tool Technologies, Ltd.
TM-85D
PL-62

Locally Supported By:

www.elliott-tool.com/support